



TECHNIQUE
WHEEL CARE EQUIPMENT

PREMIUM BRANDING

Bullworthy will only offer recognised premium workshop equipment. Premium brands not only ensure the highest possible standard for products, but will prove more reliable and efficient in use, reduce the cost of long-term ownership and will, most importantly, generally be safer to use. Exceeding the strict demands of CE approval, and having endured rigorous factory proving and field testing, are examples of the criteria inherent in the equipment we offer.

Bullworthy are pleased to be able to offer the exclusive *'Technique'* range of garage equipment products. *Technique*, offers state of the art and prestigious MOT testing installations, a full range of car and commercial lifting products, tyre equipment, exhaust and dust extraction systems, jacking equipment, lubrication and compressed air systems, and workshop furniture.

Technique, is a brand that has more than twenty years of industry approval. Specifically selected, tested and maintained by 'Trade Garage Equipment', of which Bullworthy form a leading role of the partnership, enabling complete UK wide coverage for sales and service.



TECHNIQUE





T2020-2D Wheel Balancer

The Technique T2020-2D is a low speed balancer with all of the features and benefits of a 'High end' machine.

The Backlit LCD screen with multifunctional and interactive keys makes it clear and easy for the operator to use.

The compact design means that the T2020-2D takes up very little space in the workshop.

The 2D caliper arm automatically stores the distance and diameter measurements and makes it easy to position the weights directly into place.

- **Motorised wheel balancer.**
- **Automatic 2D caliper arm rim diameter/distance.**
- **Brake Pedal-operated main shaft lock.**
- **Low rotation speed.**
- **Automatic ALU S programme.**
- **Backlit LCD display with multifunctional and interactive keys.**
- **Easy start by closing wheel guard or pressing the start key and auto stop.**
- **Brake to keep the wheel in position while fitting the weights.**

Rim Diameter	10" - 26" Automatic / 10" - 30"
Rim Width	1.5" - 22"
Max Wheel Weight	65kg
Read-out Accuracy	1g
Cycle Time	6 seconds
Rotation Speed (RPM)	< 100
Power Supply	110-230v / 50-60/1ph

Standard Accessories Kit Included: Standard Cones(x4), hand-wheel quick fit nuts, pilers, wheel width caliper and 4WD cone adaptor.

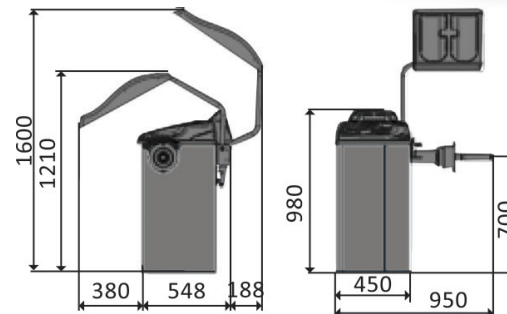

Auto distance and diameter measurement.

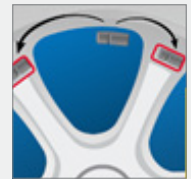

Hidden weight mode.

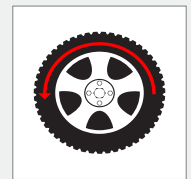

Rim and tyre optimisation.



Backlit graphical LCD display.



T2030-3D Wheel Balancer

The Technique T2030-3D is a Fully automatic 3D Balancer designed to fit into any high volume tyre shop.

Laser pointing accuracy for weight positioning, the Caliper arm and 3D Sonar arm gives quick automatic distance, diameter and rim width measurements.

- 19" industrial monitor.
- Run out measurement.
- Eco Weight balancing system.
- Motorised fully automatic wheel balancer.
- Laser Pointer for accurate weight position.
- 3D Sonar arm built into the hood for automatic width measurement.
- Automatic distance and diameter measured from the caliper arm.
- Double LED lights for the inside of the rim.
- Quick automatic programme function.
- Automatic braking for both outside and inside weight position.
- Additional manual foot brake.

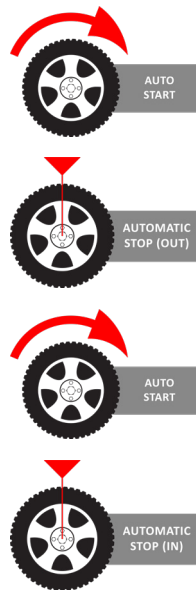

Auto distance and diameter measurement.



Automatic programme selection.



Double LED placement.

Rim Diameter	10" - 26" Automatic
Rim Width	1.5" - 22"
Max Wheel Weight	70kg
Read-out Accuracy	1g
Cycle Time	6 seconds
Rotation Speed (RPM)	< 100
Power Supply	110-230v / 50-60/1ph

Standard Accessories Kit Included: Standard Cones(x4), hand-wheel quick fit nuts, pilers, wheel width caliper and 4WD cone adaptor.

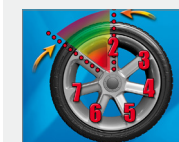
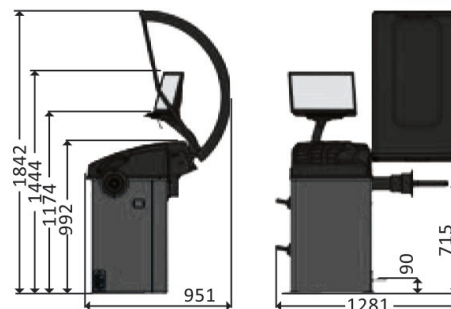

Hidden weight mode.

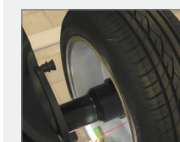

LASER-BLADE weight positioning.



T2210-PRO Tyre Changer

The Technique T2210-PRO Fully automatic 22" tyre changer will meet the highest of demands from any operator.

The Tilt back extra high turret allows extra space for working on deeper wheels up to a 17" width.

Side assist arm is supplied with three adaptor arms. Side bead breaker with adjustment for the wider wheel.

- Fully automatic tyre changer with high turret.
- Extra rigid 4 jaw clamping table.
- Adjustable side bead breaker.
- Plastic inserts for rim protection.
- Side assistance arm.
- Auto tilt back arm.

Motor	0,75 Kw - 230/400V (50-60Hz) - 3ph
Chuck rotation speed (rev/min)	7,3 rpm / 6,5/13 rpm
Max torque to chuck	1200 Nm (885 FtLbs)
External clamping	11"-22"
Internal clamping	13"-24.5"
Tool working span	8"-32"
Max tyre diameter	1050 mm (41")
Max rim width	318 mm (15")
Bead breaker cylinder power @ 12 bar	3600 kg (8000 lbs)

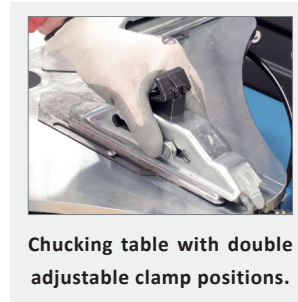

Chucking table with double adjustable clamp positions.

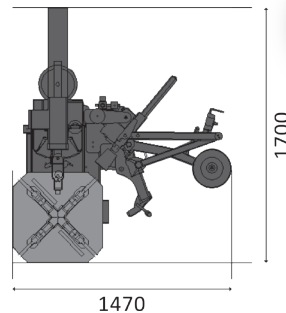

1050mm
(41")



381mm
(15")

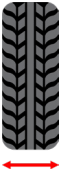



T2220-M1 Tyre Changer

Max: 45"
(1143mm)



10" - 26"



15"
(581mm)



The Technique Memory 1 should not be mistaken for any standard tyre changer. This completely lever less tyre changer makes easy work of changing any low profile, run flat or standard tyre.

The memory function allows the vertical roller bead breaker and demount head to go back to the same rim position at the push of a pedal.

The height adjustable center post clamping system allows for reverse rims to be positioned without any damage to your customers rim. The variable speed motor allows slower speeds for low profile tyres.

- Memory positioning of demount head and bead breaker.
- Adjustable height center post clamping.
- Space saving vertical turret as no tilt back required.
- Variable speed motor for the tight tyres.
- Conventional side bead breaker.
- Vertical roller bead breaker.
- Integral pneumatic wheel lift.
- Side assist arm.

Rotation Speed (rev/min)	7,3 6,5/13 (V) 0-16 (D)
Max Torque	1200 Nm
Recommended Air Supply	8 / 10 bar
Max Wheel Diameter	45"/1143 mm
Max Wheel Width	381 mm (15")
Max Side Shovel Bead Loosener Opening	432 mm (17")
Handles Wheels From	10" - 26"
Rotation Motor	1,5 Kw inv.+ 0,75kw motor
Bead Loosener Power (roller)	1200 kg (2645 lbs)
Bead Loosener Power (side shovel)	3600 kg (7900 lbs)
Noise Level	<80db

Easy Demount Head (Upper Bead):
Bead controls up and down and the bead is demounted.

Pneumatic assist arm.

Space saver: Post with vertical space saver movement.

Self locking clamp system.

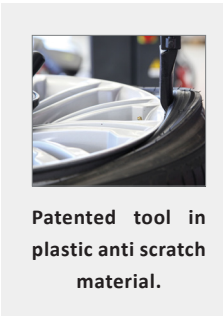

Patented tool in plastic anti scratch material.

Foot pedal tyre inflation.

Wheel lifter.

Variable speed control.

Tool memory:
Rim edge memory controls. Place it first time, then it will go back to same position by just pushing a pedal.

Switch for quick opening or arm.

Easy bead breaking:
380 degree breaker and alternative side breaker.

Two position locking plate for standard or reverse rims.

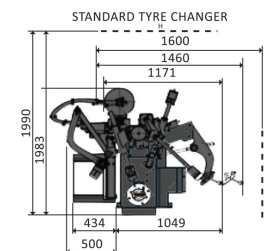
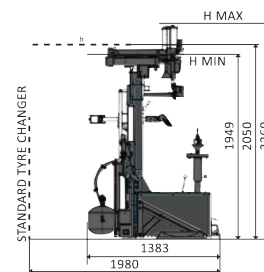



T2230-M2 Tyre Changer



The **Technique Memory 2** is the Ultimate tyre changer. This truly fully automatic and lever less tyre changer is the perfect match for any high volume / high end tyre shop.

The **Memory function** sets both the demount head and the bead breaker arms to the rims width at the touch of a button. The centre post clamping system rules out any chance of damaging your customers alloy wheel and allows you to work on any size standard or reverse rim.

The **Auto touch** function on the top and bottom vertical roller bead breaker arms makes light work of the bead. The unique patented leverless demount head automatically guides itself between the tyre and rim and removes the tyre with minimum stress on the wheel.

The 3 stage height adjustable centre clamping system allows you to work on the largest tyres on the market place. The pneumatic wheel lift takes all the heavy work out of changing a tyre.

Handled Wheels	10"-30" / 12"-32" /14"-34"
Weight	370 kg
Max Wheel Width	15"
Max Wheel Diameter	1370 mm (54")
Bead Breaker Power Per Arm	1200 kg
Max Torque	120 Kgm
Bead Breaker Movement	Automatic
Rotation Motor	1,5 Kw inemotor +0,75 Kw motor
Recommended Air Supply	8 -10 bar
Power Supply	1ph, 180/260v, 50/60Hz



A sensor automatically activates bead breaker which operates in the correct position and not on rim side. Bead breaking of both sides is quickly performed.

Unique auto-touch function: Can operate on normal and reverse rims. Run Flat, SST & PAX.

Space saving design.

Pneumatic assist arm.



Easy Controls:

- 1: Upper roller & rim sensor.
- 2: Lower roller & rim sensor.
- 3: Upper tool.
- 4: Lower tool.
- 5: Tool position memory.

0-15 RPM variable speed:

Equipped with unique innovative inverter which allows to regulate chucking table rotation pedal. Slows down rotation speed as stress on bead increases, avoiding any damage to tyre.

Three adjustable working heights.

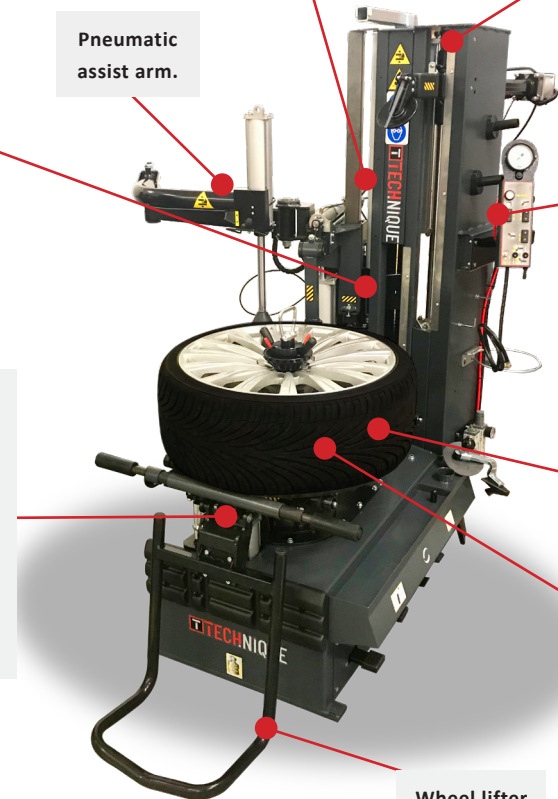

Unique self-locking plate.

Wheel lifter

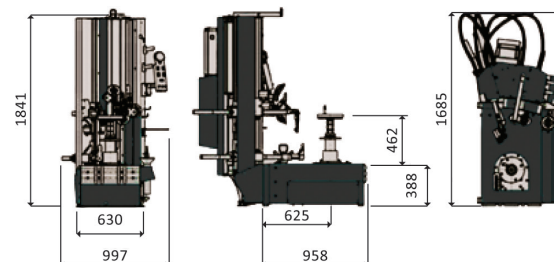

Quick fit rim clamping system: Fast clamping of normal and reverse rims.

Quick diameter setting: Diameter checking in a single move. Pneumatic, synchronised adjustment of four arms to suit wheel diameter.

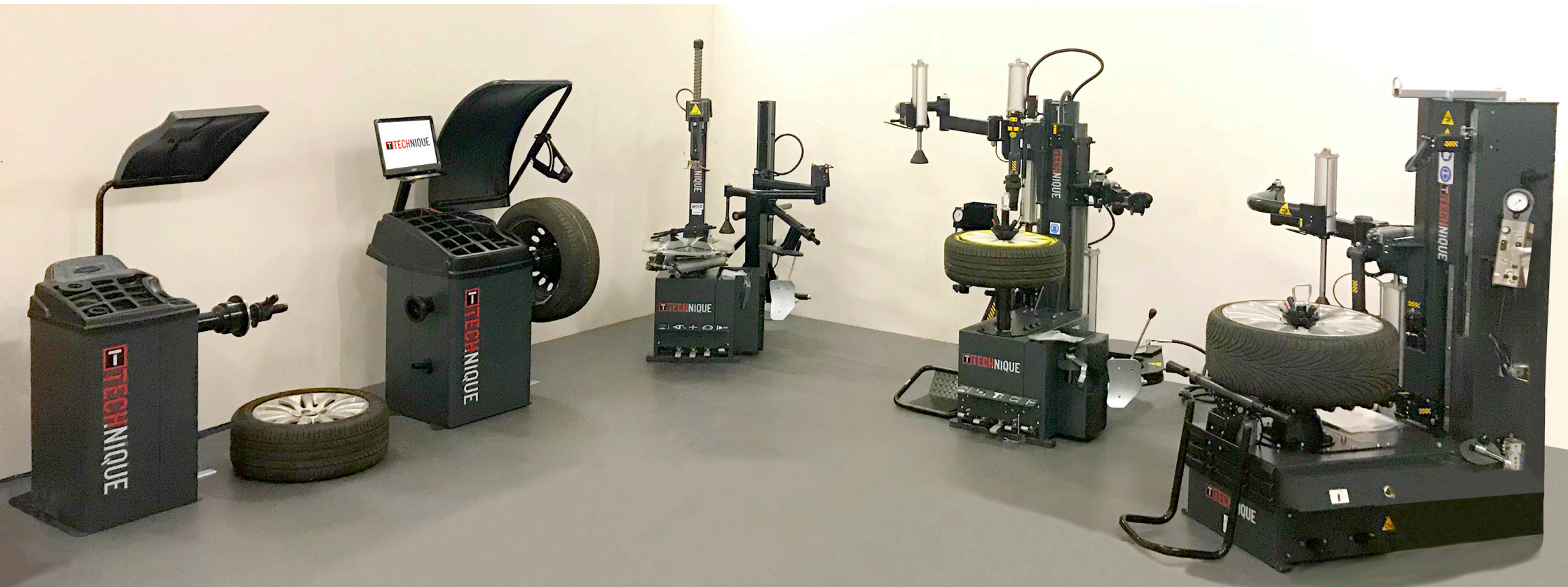

MAIN OFFICE: T.R BULLWORTHY LTD. UNIT 7, MANOR BUSINESS PARK, WOODFORD HALSE, NORTHAMPTONSHIRE, NN11 3UB

 (01295) 768 373  enquiries@bullworthy.co.uk  www.bullworthy.co.uk